

SPECIFICATIONS FOR LCD MODULE

MODEL NO.
BG12864E-YRNNH3T\$000
VER.01



FOR MESSRS:

ON DATE OF:

APPROVED BY:

BOLYMIN, INC.

5F, No. 38, Keya Rd., Daya Dist., Central Taiwan Science Park, Taichung City, 42881, Taiwan.

Web Site: <http://www.bolymin.com.tw> TEL:+886-4-25658689 FAX:+886-4-25658698

CONTENTS

1. Numbering System
2. Handling Precaution
3. General Specification
4. Absolute Maximum Rating
5. Electrical Characteristics
6. Optical Characteristics
7. Interface Pin Function
8. Power supply for LCD Module and LCD operating voltage adjustment
9. Backlight information
10. Quality Assurance
11. Reliability
12. Appendix (Drawing , IC controller data)
 - 12-1 Drawing
 - 12-2 IC controller data
 - 12-2.1 Display Control Instruction
 - 12-2.2 Timing characteristics

1. Numbering System

B	G	12864	E	-	Y	R	N	N	H	3T	\$	000
0	1	2	3		4	5	6	7	8	9	10	11

0	Bolymin	B										
1	Module Type	C	Character type	P	TAB /TCP type							
		F	COF type	R	Color STN							
		G	Graphic type	L	OLED							
		O	COG type	Z	Customize							
2	Format	2004		20 character type,4lines								
		12232		122 × 32 dots								
3	Version No.	E										
		-										
4	LCD Color	B	STN / Blue, OLED/Blue	H	HTN							
		C	Color	T	TN							
		F	FSTN	Y	STN/Yellow-green							
		G	STN/Grey	D	OLED/Blue+Yellow							
		A	OLED/Blue+Yellow+Green	E	OLED/Yellow							
		L	OLED/Green	R	OLED/RED							
		W	OLED/White	J	ASTN							
		K	DFSTN	V	VA LCD							
5	LCD Type	R	Positive/reflective	M	Positive/ transmissive							
		P	Positive/transflective	N	Negative/ transmissive							
		T	Negative/ transflective									
6	Backlight type/color	L	(LED)Array/yellow-green	G	(LED)Edge/yellow-green							
		M	(LED)Array/amber	H	(LED)Edge/white							
		R	(LED)Array/red	D	(LED)Edge/blue							
		U	(LED)Array/blue	E	(EL)white							
		W	(LED)Array/white	B	(EL)blue							
		C	(CCFL) white	F	(LED)Array/RGB							
		Y	(LED)Array/yellow	N	No backlight							
		O	(LED)Array/orange	K	(LED)Edge/green							
		A	(LED)Edge/amber	Q	(LED)Edge/red							
		J	(LED)Array/green	I	(LED)Edge/RGB							
		Z	(LED) arrayred/green	P	(LED)Edge/orange							

		S	(LED)edge/RGW	T	(LED)edge red/green
		V	EL blue/green	X	(LED) Edge white /red
7	CGRAM Font	J	English/Japanese Font	C	English/Cyrillic Font
		G	Chinese(simple)	H	English/Hebrew Font
		E	English/European Font (ST7066U0B-BB)	S	English/European Font (ST7066U-0E-BB)
		F	Chinese(traditional)	M	Japanese-Kanji
		Z	Z=Chinese(simple)+Chinese (traditional)+Japanese+Korean	K	Korean (only for BG16032A BG24064C)
		A	English/Arabic Font	D	Chinese (simple/traditional) English/Japanese
		B	English/Japanese/European	N	None
8	View Angle /Operation Temperature	B	Bottom/Normal Temperature 06:00	W	Top/Wide Temperature 12:00
		H	Bottom/Wide Temperature 06:00	E	Top/Ultra Temperature 12:00
		C	9H/Normal Temperature 09:00	U	Bottom/Ultra wide Temperature 06:00
		T	Top/Normal Temperature 12:00	F	9H/Ultra wide Temperature 09:00
		G	3H/Wide Temperature 3:00	D	9H/Wide Temperature 09:00
		I	3H/ Ultra Wide Temperature 3:00		
9	Special Code	N	Negative voltage for LCD	T	Negative voltage and Temperature compensation for LCD
		P	Touch panel	3/5	3/5 voltage logic power supply
10	RoHS	\$			
11	Customer Code	000= AVANT SBN6400G+SBN0064G IC			

2. Handling Precaution

2.1 Precaution in use of LCD Module

- 2.1.1. LCD panel is made of glass. Avoid excessive mechanical shock or applying strong pressure and/or sharp tools on the surface of display area.
- 2.1.2. The polarizer placed on the display surface is easily scratched and damaged. Extreme care should be taken when handling it. To clean dust or dirt off the display surface, wipe gently with cotton, or other soft material soaked with isopropyl alcohol, ethyl alcohol, do not use water, ketone or aromatics to clear display surface, and never scrub it hard.
- 2.1.3. Keep LCD panels away from direct sunlight. The storage environment should be dust-free, clean, dry, temperature is $25^{\circ}\text{C}\pm 10^{\circ}\text{C}$ and the humidity is below 55% RH.
- 2.1.4. Do not input any signal before power is turned on.
- 2.1.5. Avoid pressing on the metal bezel, otherwise the elastomer connector could be deformed and lose contact, resulting in missing pixels and also cause rainbow on the display.
- 2.1.6. It's important to control soldering temperature and time. RoHS compliant materials might need higher temperature and time, but try to keep temperature under 350°C and time in 3-5 sec.
- 2.1.7. EL is manufactured from the organic film, and is easily affected by temperature, humidity and other environmental impact. Long time storage might cause low quality of the case. Therefore, please start production in 3 months after reception of the LCM. If in any case, long time storage over 3 months is necessary, please keep EL in vacuum package or at least in humidity $< 35\%$ RH, and temperature $25^{\circ}\text{C}\pm 10^{\circ}\text{C}$.
Note: 2.1.7. is applied to EL backlight only.

2.2 Static Electricity Precautions:

- 2.2.1. The LCD module contains a C-MOS LSI. People who operate the LCM should wear ESD protection equipment to prevent ESD hurt on products.
- 2.2.2. Do not touch any of the conductive parts such as the LSI pads; the copper leads on the PCB and the interface terminals with any parts of the human body.
- 2.2.3. Do not touch the connection terminals of the display with bare hand; it will cause disconnection or defective insulation of terminals.
- 2.2.4. The modules should be kept in anti-static bags or trays for storage.
- 2.2.5. Only properly grounded soldering irons should be used.
- 2.2.6. If an electric screwdriver is used, it should be grounded and shielded to prevent sparks.
- 2.2.7. The normal static prevention measures should be observed for work clothes and working benches.
- 2.2.8. Since dry air(almost low RH) is inductive to static, a humidity of 50-60% RH is recommended in assembly line.

2.3 Operation Precautions:

- 2.3.1. DC voltage applied on LCM causes electrochemical reactions, which will deteriorate the display over time. The applied pulse waveform should be a symmetric waveform such that no DC component remains. Be sure to use the specified operating voltage.
- 2.3.2. LCD driving voltage should be kept within specified range; excess voltage will shorten display life, while less voltage may not turn on LCM.
- 2.3.3. LCM response time will be extremely delayed in low operating temperature(such as -20°C) than in room operating temperature. Therefore, higher LCD driving voltage is required in low operating temperature; On the other hand, in high operating temperature (such as $+70^{\circ}\text{C}$) LCD shows dark background color, therefore lower LCD driving voltage is required. Be sure to use the specified LCD driving voltage in different operating temperature.

2.4 Safety:

- 2.4.1 If the LCD panel breaks, be careful not to get the liquid crystal to touch your skin.
If the liquid crystal touches your skin or clothes, please wash it off immediately by using soap and water.

2.5 WARRANTY POLICY

Bolymin .Will provide one-year warranty for the products only if under specification operating conditions.

If there are functional defects found during the period of warranty, the defective products would be replaced on a one-to-one basis.

Bolymin would not be responsible for any direct/indirect liabilities consequential to any parties.

2.6 MTBF

- 2.6.1 .By specific test condition, MTBF based on 30°C normal operation temperature is 50,000hours.

2.6.2 Test Condition:

2.6.2.1 Supply Voltage for LCM: Typical Vdd

2.6.2.2 CC (Constant Current) mode and typical current is applied for LED.

2.6.2.3 Run-Patterns: by Bolymin's test program that has defined patterns and cyclic period.

2.6.2.4 Humidity: 60%RH

2.6.3 Test Criteria:

Attenuation of average brightness: $\leq 50\%$

Increasing of current consumption for LCM/Backlight: $\leq 20\%$

Display function at room temperature: Normal

Appearance: Normal

3. General Specification

(1) Mechanical Dimension

Item	Standard Value	Unit
Number of dots	128x64	dots
Module dimension (L*W*H)	75.0 x 52.7 x 8.4	mm
View area	60(W)x32.6(H)	mm
Active area	55.0(W)x27.48(H)	mm
Dot size	0.39(W)x0.39(H)	mm
Dot pitch	0.43(W)x0.43(H)	mm

(2) Controller IC: AVANT SBN6400G+SBN0064G

4. Absolute Maximum Rating

4.1 Electrical Absolute Maximum Ratings

(V_{SS}=0V, T_a=25°C)

Item	Symbol	Min	Typ	Max	Unit
Input Voltage	V _I	0	—	V _{DD}	V
Supply Voltage For Logic	V _{DD}	0	—	5.5	V
Supply Voltage For LCD	V _{DD} -V _{EE}	0	—	16.0	V
Supply Voltage For LCD	V _{EE}	—	—	-10	V

4.2 Environmental Absolute Maximum Ratings

Item	Symbol	Min	Max	Unit	Note
Operating Temperature	TOP	-20	70	°C	(1)
Storage Temperature	TST	-30	80	°C	(1)

Note (1)

- (a) 90 %RH Max. ($T_a \leq 40$ °C).
- (b) Wet-bulb temperature should be 39 °C Max. ($T_a > 40$ °C).
- (c) No condensation.

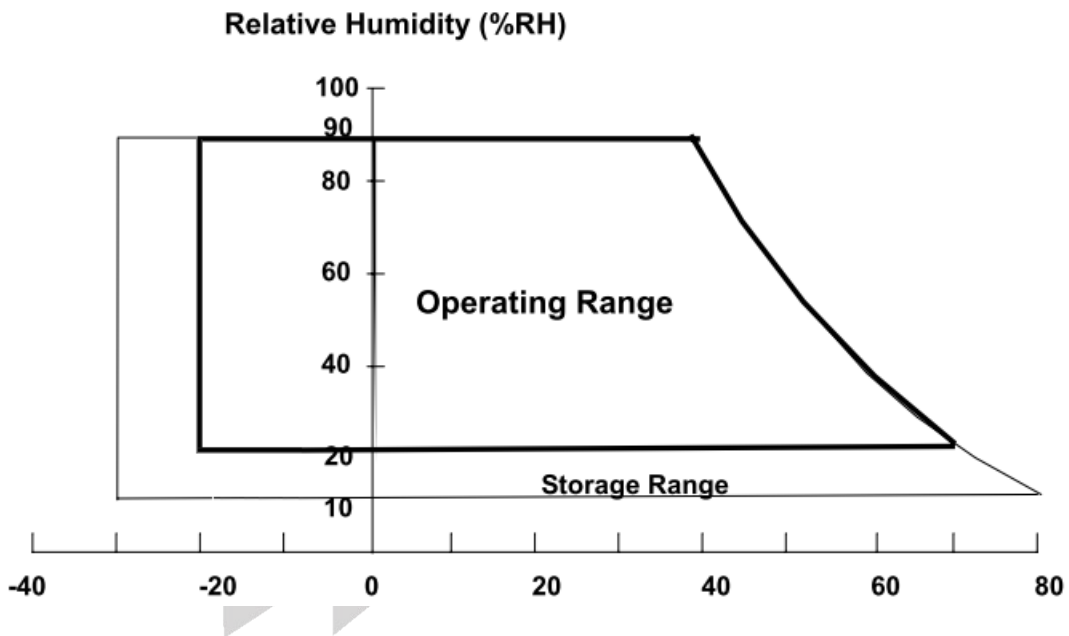

5. Electrical Characteristics

Item	Symbol	Condition	Min.	Typ.	Max.	Unit
Supply Voltage For Logic	$V_{DD}-V_{SS}$	—	—	3.3	—	V
Supply Voltage For LCD	$V_{DD}-V_0$	Ta=25°C	8.2	8.5	8.8	V
Input High Vol	V_{IH}	—	$V_{DD}-2.2$	—	V_{DD}	V
Input Low Vol	V_{IL}	—	0	—	0.8	V
Output High Vol	V_{OH}	—	$V_{DD}-0.3$	—	V_{DD}	V
Output Low Vol.	V_{OL}	—	0	—	0.3	V
Supply Current	I_{DD}	—	—	10.0	—	mA

※Optimum LCD driving voltage value, referring to above mentioned range, is changed due to different batch of LCD glass.

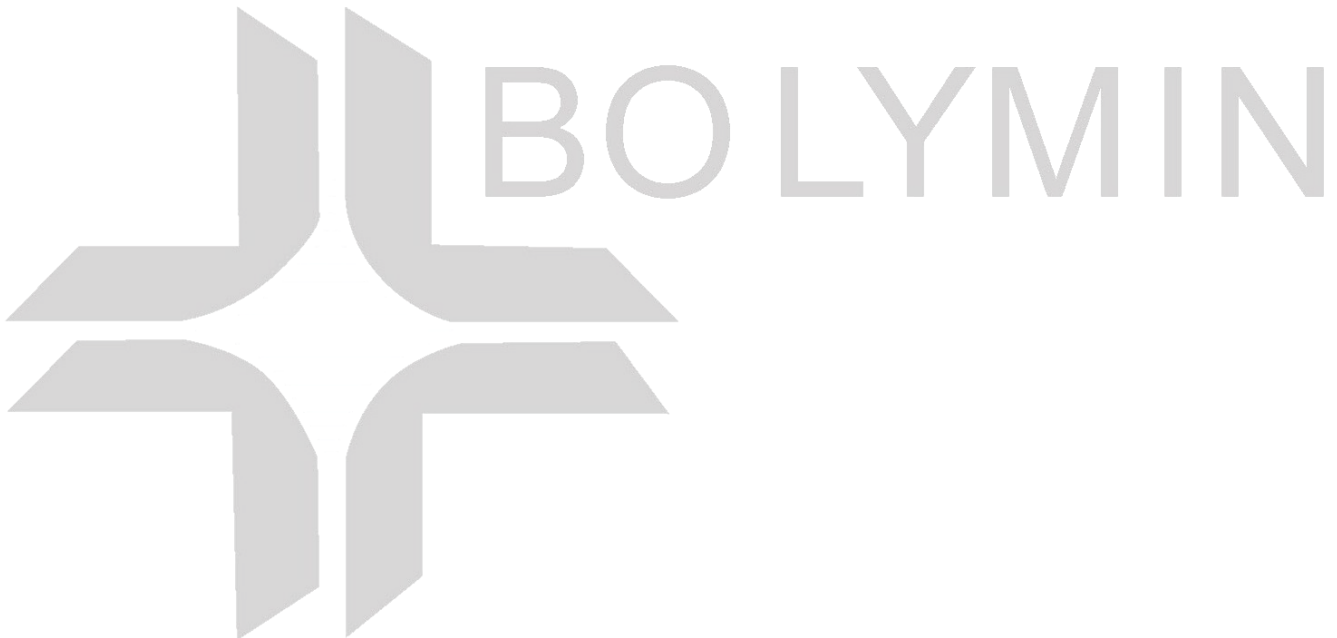

6. Optical Characteristics

a. STN

($T_a=25^{\circ}\text{C}$)

Item	Symbol	Min.	Typ.	Max.	Unit
View Angle (CR \geq 2)	θ_F	-	30	-	deg
	θ_B	-	35	-	deg
	φ_L	-	38	-	deg
	φ_R	-	40	-	deg
Contrast Ratio	CR	2	3	-	-
Response Time 25 $^{\circ}\text{C}$	T rise	-	200	350	ms
	T fall	-	200	400	ms

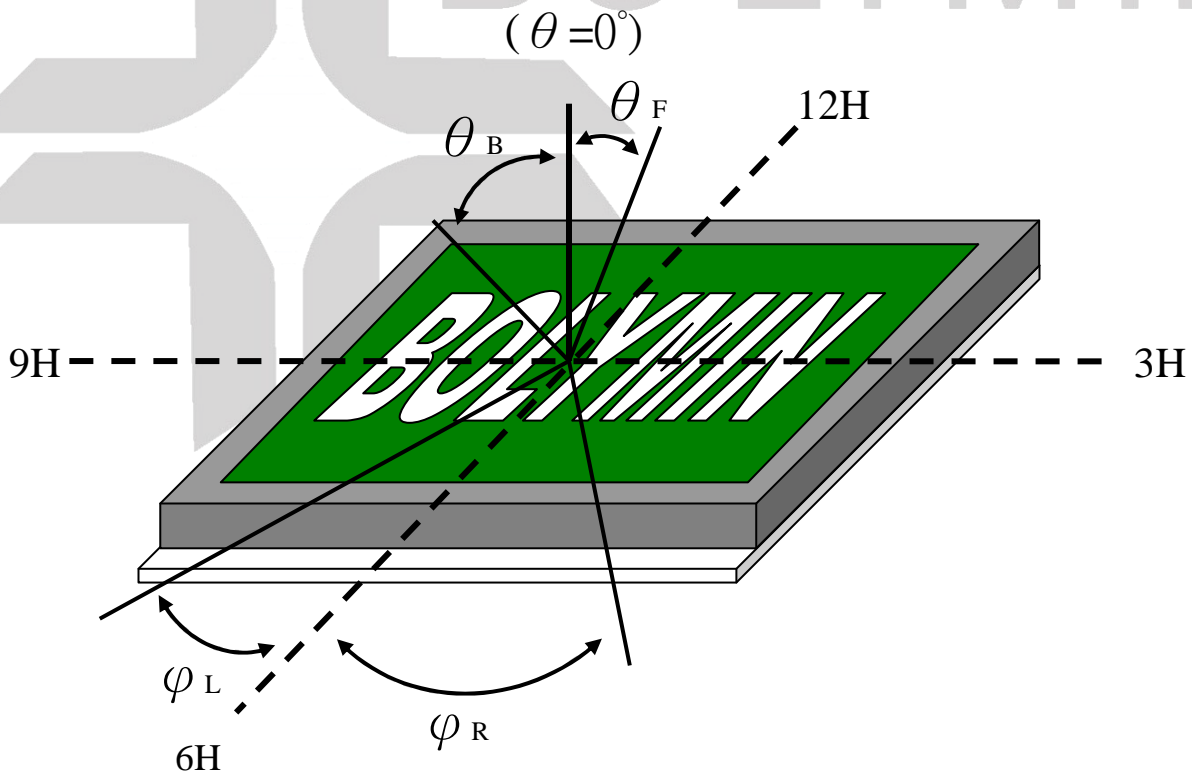

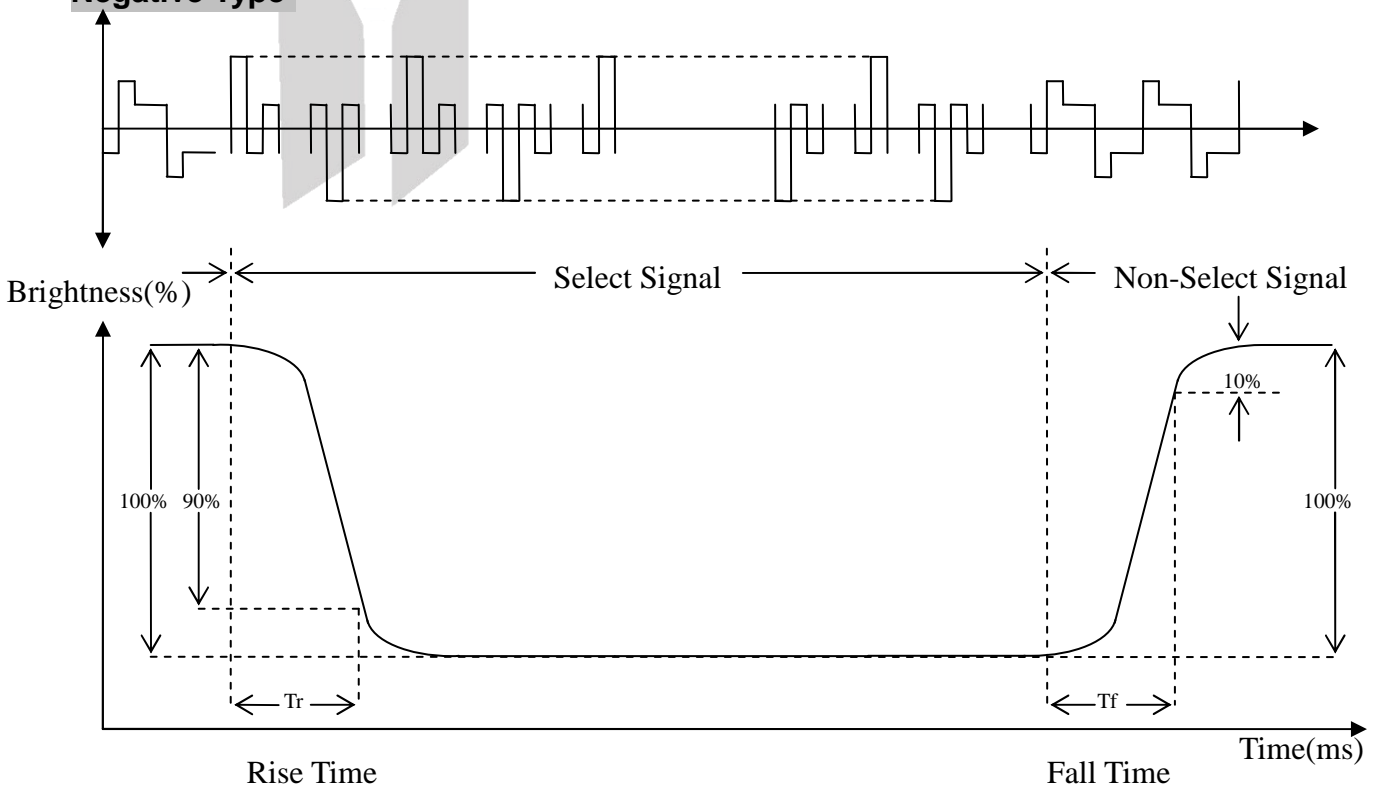
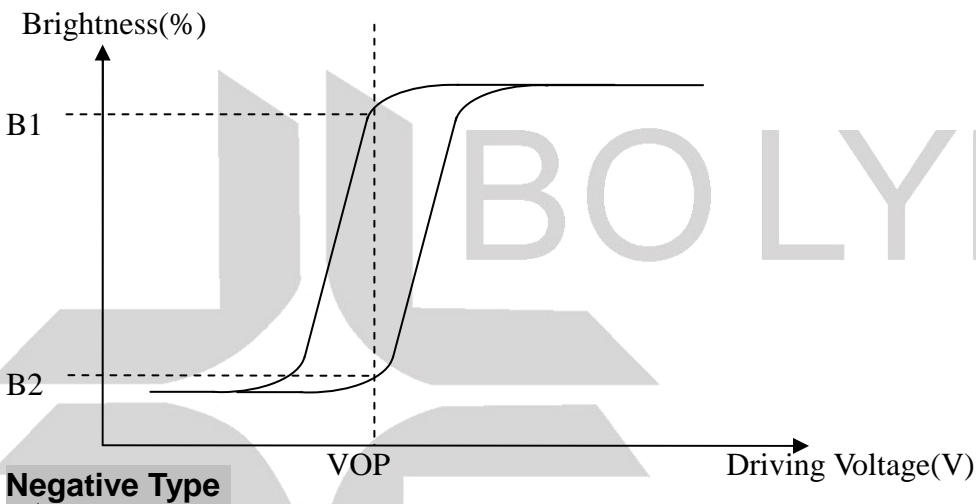
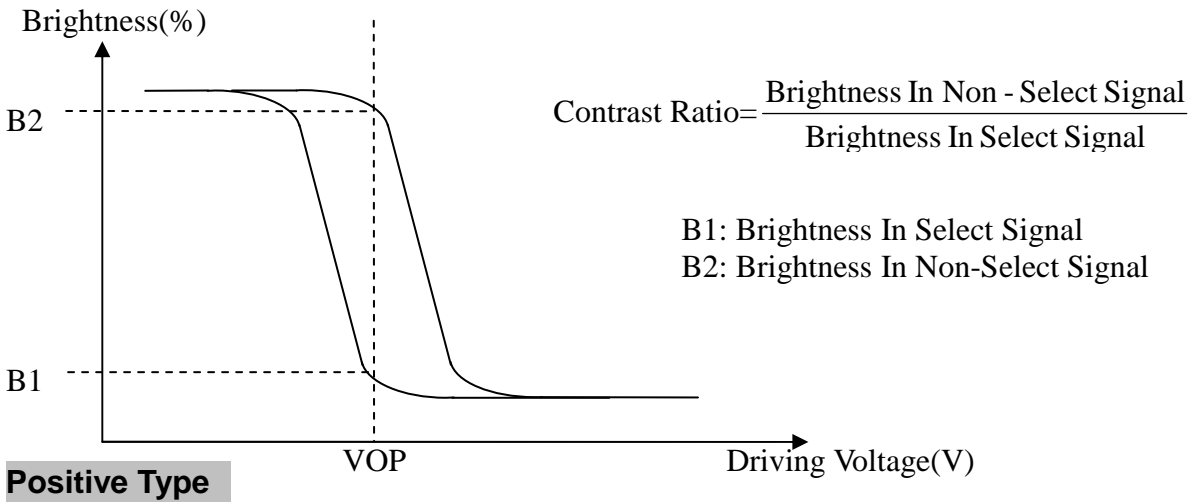

7. Interface Pin Function

Pin No.	Symbol	Level	Description
1	V _{dd}	3.3V	Supply voltage for logic
2	GND	0V	Ground
3	V _o	(Variable)	Operating voltage for LCD
4	DB0	H/L	Data bus line
5	DB1	H/L	Data bus line
6	DB2	H/L	Data bus line
7	DB3	H/L	Data bus line
8	DB4	H/L	Data bus line
9	DB5	H/L	Data bus line
10	DB6	H/L	Data bus line
11	DB7	H/L	Data bus line
12	/CS1	L	Chip Select for IC1
13	/CS2	L	Chip Select for IC2
14	/RST	L	Reset signal
15	R/W	H/L	H=Read mode , L=Write mode
16	D/I	H/L	H=Data register , L=Instruction register
17	E	H/L	Enable signal
18	V _{ee}		Negative Voltage output -6V
19	A	—	NC
20	K	—	NC

8. Power supply for LCD Module and LCD operating voltage adjustment

LCM operating on " DC 3.3V " input with built-in negative voltage

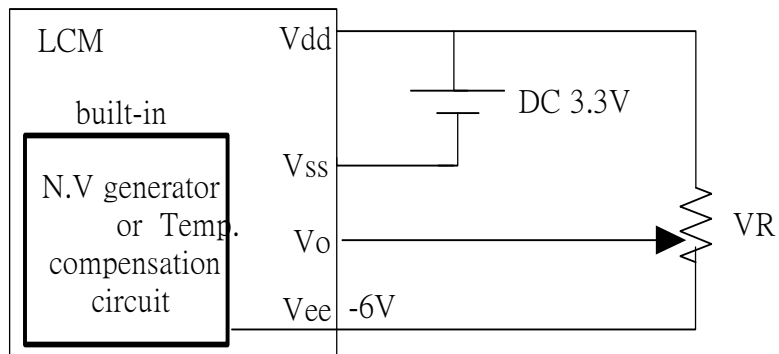

9. Backlight information

No Backlight

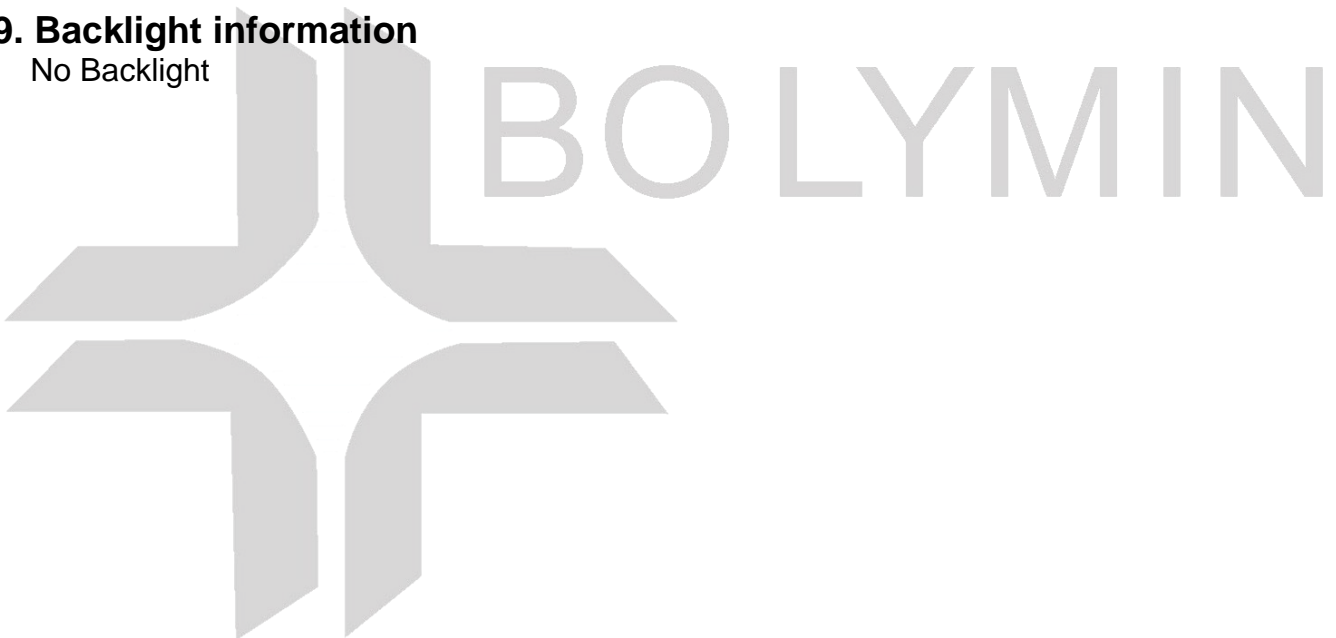

10. Quality Assurance

10.1 Inspection conditions

1. The LCD shall be inspected under 20~40W white fluorescent light.
2. Checking Direction shall be in the 40 degree from perpendicular line of specimen surface.
3. Checker shall see over 30 cm.
4. Inspect about 5 seconds for each side.
5. Defect that is located at outside of VA and doesn't affect function is ignored.

10.2 Inspection Parameters

NO.	Parameter	Criteria				
1	Black or White spots (Particle)	Zone		Acceptable Number	Class Of Defects	Acceptable Level
		Dimension				
		$D \leq 0.10$		Disregard	Minor	2.5
		$0.10 < D \leq 0.2$		4		
		$0.2 < D \leq 0.3$		2		
$0.3 < D$		0				
<p>$D = (\text{Long} + \text{Short}) / 2$ Total defects should not exceed 5/module Defect that is located at outside of AA and doesn't affect function is ignored.</p>						
2	Scratch, Substances	Zone		Acceptable Number	Class Of Defects	Acceptable Level
		X(mm)	Y(mm)			
		—	$0.05 \geq W$	Disregard	Minor	2.5
		$4.0 \geq L$	$0.05 \geq W$	4		
		$3.0 \geq L$	$0.1 \geq W$	2		
—	$0.1 < W$	0				
<p>X: Length Y: Width Total defects should not exceed 5/module Defect that is located at outside of AA and doesn't affect function is ignored.</p>						

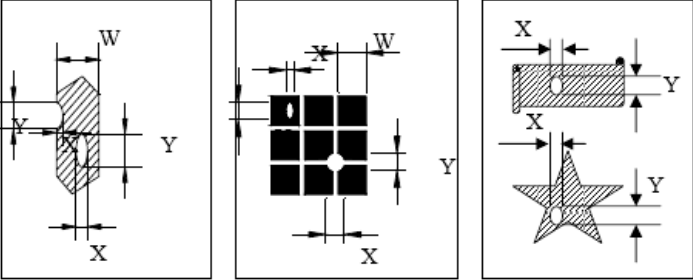
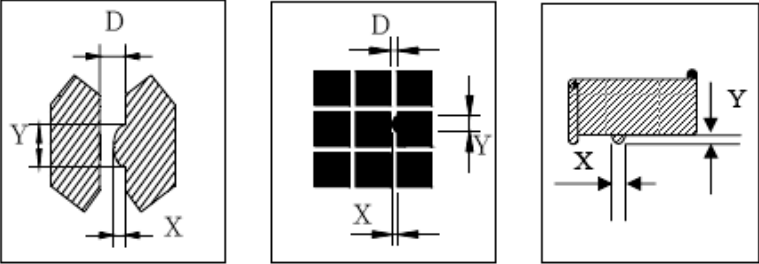
3	Air Bubbles (between glass & polarizer)	<table border="1"> <tr> <th>Zone Dimension</th> <th>Acceptable Number</th> <th>Class Of Defects</th> <th>Acceptable Level</th> </tr> <tr> <td>$D \leq 0.2$</td> <td>Disregard</td> <td rowspan="3">Minor</td> <td rowspan="3">2.5</td> </tr> <tr> <td>$0.2 < D \leq 0.5$</td> <td>3</td> </tr> <tr> <td>$0.5 < D$</td> <td>0</td> </tr> </table>	Zone Dimension	Acceptable Number	Class Of Defects	Acceptable Level	$D \leq 0.2$	Disregard	Minor	2.5	$0.2 < D \leq 0.5$	3	$0.5 < D$	0														
Zone Dimension	Acceptable Number	Class Of Defects	Acceptable Level																									
$D \leq 0.2$	Disregard	Minor	2.5																									
$0.2 < D \leq 0.5$	3																											
$0.5 < D$	0																											
<p>Total defects shall not excess 3/module. Defect that is located at outside of AA and doesn't affect function is ignored. Bobbles seen only under reflection light is disregarded.</p>																												
4	Displaying Pattern	<p>1. Incomplete or broken line is not allowed. 2. Pinholes</p> <table border="1"> <tr> <th>Dimension Φ(mm)</th> <th>Criteria</th> <th>Class Of Defects</th> <th>Acceptable Level</th> </tr> <tr> <td>$\Phi < 0.1$</td> <td>Disregard</td> <td rowspan="4">Minor</td> <td rowspan="4">2.5</td> </tr> <tr> <td>$0.1 < \Phi \leq 0.2$</td> <td>2</td> </tr> <tr> <td>$0.2 < \Phi \leq 0.25$</td> <td>1</td> </tr> <tr> <td>$0.25 < \Phi$</td> <td>0</td> </tr> </table>  <p style="text-align: center;">$\phi = (X+Y)/2$</p> <p>3. Deformation</p> <table border="1"> <tr> <th>Dimension Φ(mm)</th> <th>Criteria</th> <th>Class Of Defects</th> <th>Acceptable Level</th> </tr> <tr> <td>$\Phi < 0.15$</td> <td>Disregard</td> <td rowspan="3">Minor</td> <td rowspan="3">2.5</td> </tr> <tr> <td>$\Phi \leq 0.25$ and $X \leq 1/2D$</td> <td>3</td> </tr> <tr> <td>$\Phi > 0.25$ and $X > 1/2D$</td> <td>0</td> </tr> </table>  <p style="text-align: center;">D : 间距</p> <p style="text-align: center;">$\phi = (X+Y)/2$</p>	Dimension Φ (mm)	Criteria	Class Of Defects	Acceptable Level	$\Phi < 0.1$	Disregard	Minor	2.5	$0.1 < \Phi \leq 0.2$	2	$0.2 < \Phi \leq 0.25$	1	$0.25 < \Phi$	0	Dimension Φ (mm)	Criteria	Class Of Defects	Acceptable Level	$\Phi < 0.15$	Disregard	Minor	2.5	$\Phi \leq 0.25$ and $X \leq 1/2D$	3	$\Phi > 0.25$ and $X > 1/2D$	0
Dimension Φ (mm)	Criteria	Class Of Defects	Acceptable Level																									
$\Phi < 0.1$	Disregard	Minor	2.5																									
$0.1 < \Phi \leq 0.2$	2																											
$0.2 < \Phi \leq 0.25$	1																											
$0.25 < \Phi$	0																											
Dimension Φ (mm)	Criteria	Class Of Defects	Acceptable Level																									
$\Phi < 0.15$	Disregard	Minor	2.5																									
$\Phi \leq 0.25$ and $X \leq 1/2D$	3																											
$\Phi > 0.25$ and $X > 1/2D$	0																											

Other Inspection standard reference Bolymin standard.

11. Reliability

■Content of Reliability Test

Environmental Test				
No	Test Item	Content of Test	Test Condition	Applicable Standard
1	High Temperature storage	Endurance test applying the high storage temperature for a long time.	80°C 96 hrs	—
2	Low Temperature storage	Endurance test applying the high storage temperature for a long time.	-30°C 96 hrs	—
3	High Temperature Operation	Endurance test applying the electric stress (Voltage & Current) and the thermal stress to the element for a long time.	70°C 96 hrs	—
4	Low Temperature Operation	Endurance test applying the electric stress under low temperature for a long time.	-20°C 96 hrs	—
5	Humidity Test	Endurance test applying the high humidity storage for a long time.	40°C, 90%RH 96hrs	—
6	Temperature cycle (Non-operation)	Endurance test applying the low and high temperature cycle. 	-30°C/80°C 10 cycles	—
7	Vibration test	Endurance test applying the vibration during transportation and using.	Total Fixed Amplitude:1.5mm Vibration Frequency :10~55Hz One cycle 60 seconds to 3 direction of X,Y,Z for each 15minutes	—

※Assess after placing at normal temperature and humidity for 4 hour ◦ No abnormalities in functions and appearance ◦

12. Appendix (Drawing , IC controller data)

12.1 Drawing

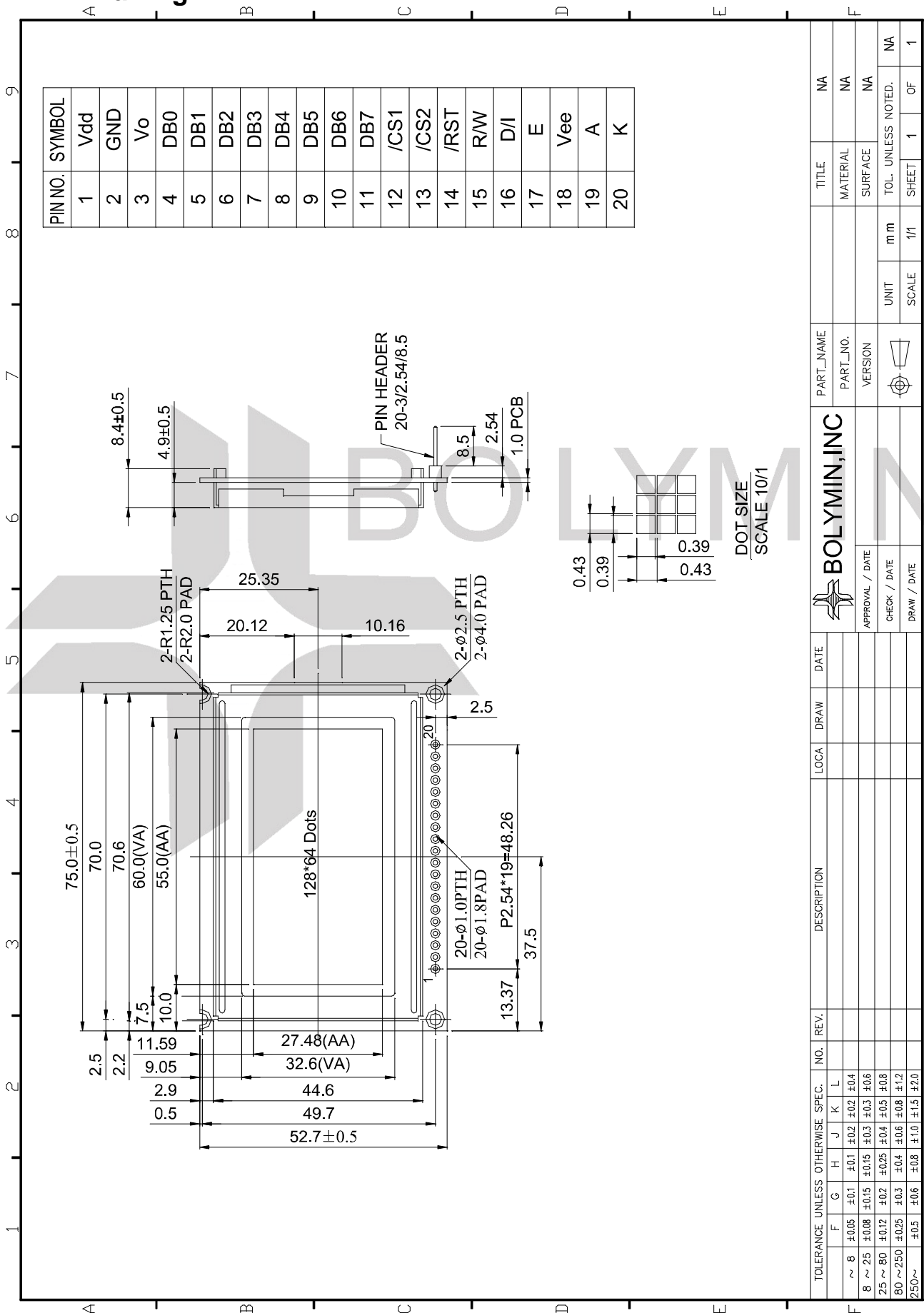

BOLYMIN, INC

APPROVAL / DATE	
CHECK / DATE	
DRAW / DATE	

TOLERANCE UNLESS OTHERWISE SPEC.	NO.	REV.	DESCRIPTION	LOCA	DRAW	DATE
~ 8	F	±0.05				
8 ~ 25	G	±0.08				
25 ~ 80	H	±0.12				
80 ~ 250	I	±0.25				
250~	J	±0.5				
	K	±0.1				
	L	±0.1				
	M	±0.1				
	N	±0.1				
	O	±0.1				
	P	±0.1				
	Q	±0.1				
	R	±0.1				
	S	±0.1				
	T	±0.1				
	U	±0.1				
	V	±0.1				
	W	±0.1				
	X	±0.1				
	Y	±0.1				
	Z	±0.1				

PART_NAME		TITLE	NA
PART_NO.		MATERIAL	NA
VERSION		SURFACE	NA
		TOL. UNLESS NOTED.	NA
UNIT	m m	SHEET	1 OF 1
SCALE	1/1		

12.2 IC controller data

12.2.1 Display Control Instruction

The display control instructions control the internal state of the SBN0064G. Instruction is received from MPU to SBN0064G for the display control. The following table shows various instructions.

Instruction	D/I	R/W	DB7	DB6	DB5	DB4	DB3	DB2	DB1	DB0	Function
Display ON/OFF	0	0	0	0	1	1	1	1	1	0/1	Controls the display on or off. Internal status and display RAM data are not affected. 0:OFF, 1:ON
Set Address	0	0	0	1	Y address (0~63)						Sets the Y address in the Y address counter.
Set Page (X address)	0	0	1	0	1	1	1	Page (0 ~7)			Sets the X address at the X address register.
Display Start Line	0	0	1	1	Display start line(0~63)						Indicates the display data RAM displayed at the top of the screen.
Status Read	0	1	B U S Y	0	R E S E T	0	0	0	0	0	Read status. BUSY 0:Ready 1:In operation ON/OFF 0:Display ON 1:Display OFF RESET 0:Normal 1:Reset
Write Data Display	1	0	Display Data								Writes data (DB0:7) into display data RAM. After writing instruction, Y address is increased by 1 automatically.
Read Data Display	1	1	Display Data								Reads data (DB0:7) from display data RAM to the data bus.

Detailed Explanation

Display On/Off

R/W	D/I	DB7	DB6	DB5	DB4	DB3	DB2	DB1	DB0
0	0	0	0	1	1	1	1	1	D

The display data appears when D is 1 and disappears when D is 0. Though the data is not on the screen with D = 0, it remains in the display data RAM. Therefore, you can make it appear by changing D = 0 into D = 1.

Display Start Line

R/W	D/I	DB7	DB6	DB5	DB4	DB3	DB2	DB1	DB0
0	0	1	1	A	A	A	A	A	A

Z address AAAAAA (binary) of the display data RAM is set in the display start line register and displayed at the top of the screen. Figure 2. shows examples of display (1/64 duty cycle) when the start line = 0-3. When the display duty cycle is 1/64 or more (ex. 1/32, 1/24 etc.), the data of total line number of LCD screen, from the line specified by display start line instruction, is displayed.

Set Page (X Address)

R/W	D/I	DB7	DB6	DB5	DB4	DB3	DB2	DB1	DB0
0	0	1	0	1	1	1	A	A	A

X address AAA (binary) of the display data RAM is set in the X address register. After that, writing or reading to or from MPU is executed in this specified page until the next page is set. See Figure 1.

Set Y Address

R/W	D/I	DB7	DB6	DB5	DB4	DB3	DB2	DB1	DB0
0	0	0	1	A	A	A	A	A	A

Y address AAAAAA (binary) of the display data RAM is set in the Y address counter. After that, Y address counter is increased by 1 every time the data is written or read to or from MPU.

Status Read

R/W	D/I	DB7	DB6	DB5	DB4	DB3	DB2	DB1	DB0
1	0	Busy	0	On/Off	RESET	0	0	0	0

•Busy

When busy is 1, the LSI is executing internal operations. No instruction are accepted while busy is 1, so you should make sure that busy is 0 before writing the next instruction.

•ON/OFF

Shows the liquid crystal display condition: on condition or off condition.

When on/off is 1, the display is in off condition.

When on/off is 0, the display is in on condition.

•RESET

RESET = 1 shows that the system is being initialized. In this condition, no instructions except status read can be accepted.

RESET = 0 shows that initializing has system is in the usual operation condition.

Write Display Data

R/W	D/I	DB7	DB6	DB5	DB4	DB3	DB2	DB1	DB0
0	1	D	D	D	D	D	D	D	D

Writes 8-bit data DDDDDDDD (binary) into the display data RAM. The Y address is increased by 1 automatically.

Read Display Data

R/W	D/I	DB7	DB6	DB5	DB4	DB3	DB2	DB1	DB0
1	1	D	D	D	D	D	D	D	D

Reads out 8-bit data DDDDDDDD (binary) from the display data RAM. Then Y address is increased by 1 automatically.

One dummy read is necessary right after the address setting. For details, refer to the explanation of output register in “Function of Each Block”.

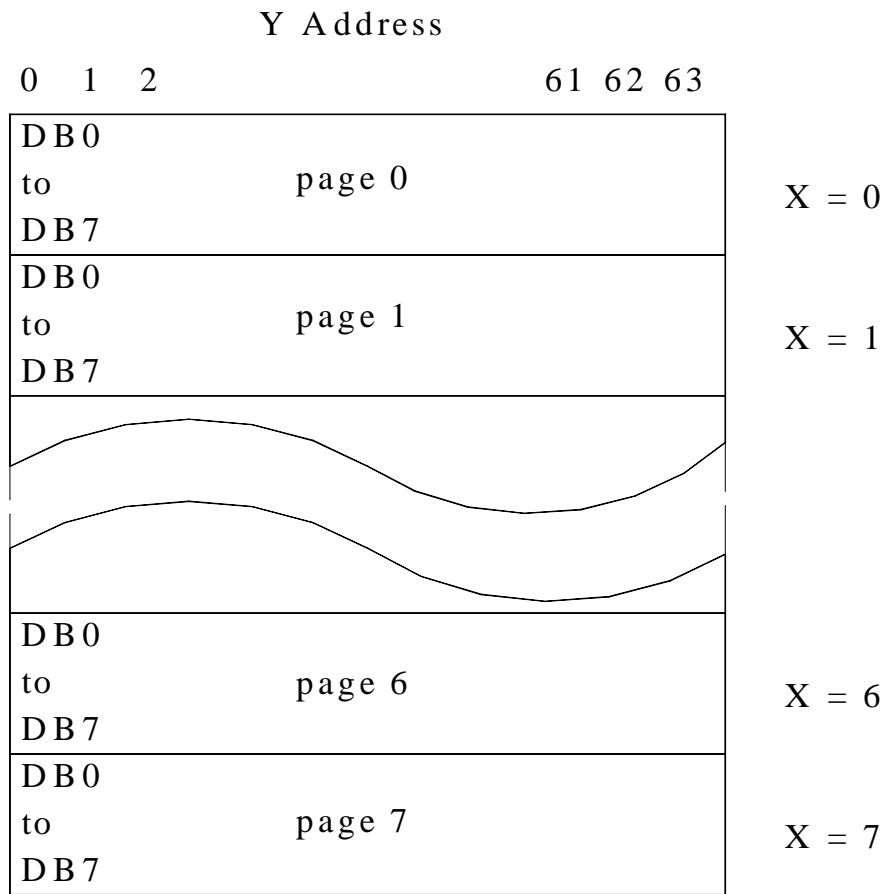
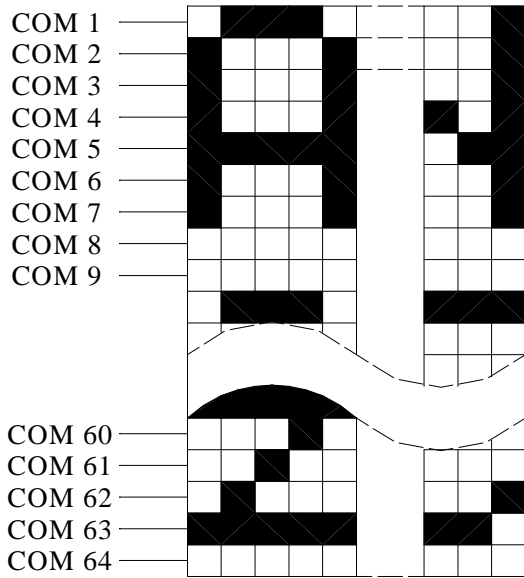
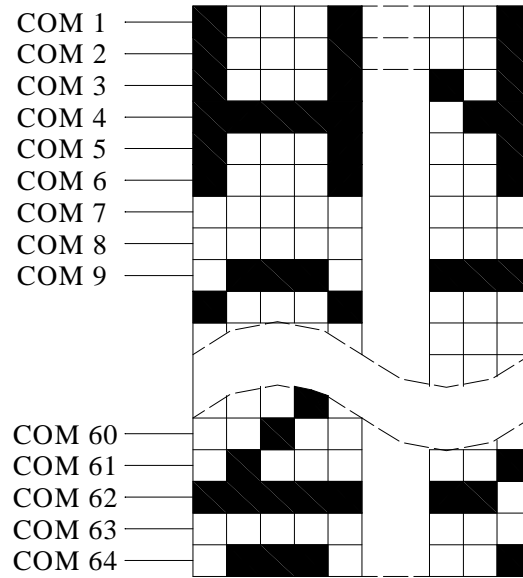

Figure 1



Start line = 0



Start line = 1

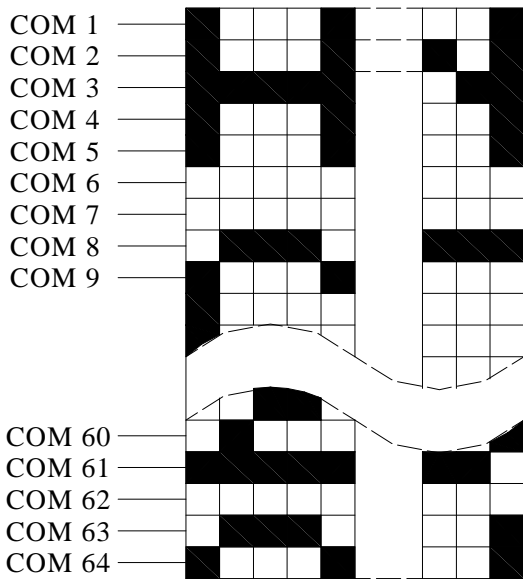

Start line = 3

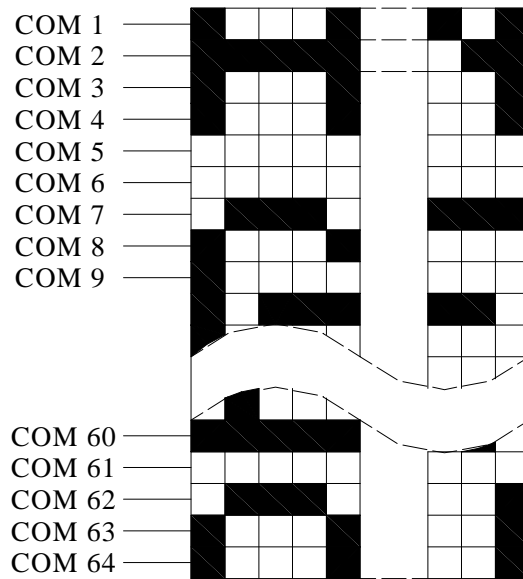

Start line = 4

Figure 2

12.2.2 Timing characteristics

MPU Interface

Characteristic	Symbol	Min	Typ	Max	Unit
E cycle	t_c	1000	—	—	ns
E high level width	t_{WH}	450	—	—	ns
E low level width	t_{WE}	450	—	—	ns
E rise time	t_R	—	—	25	ns
E fall time	t_F	—	—	25	ns
Address set-up time	t_{ASU}	140	—	—	ns
Address hold time	t_{AH}	10	—	—	ns
Data set-up time	t_{DSU}	200	—	—	ns
Data delay time	t_D	—	—	320	ns
Data hold time (write)	t_{DHW}	10	—	—	ns
Data hold time (read)	t_{DHR}	20	—	—	ns

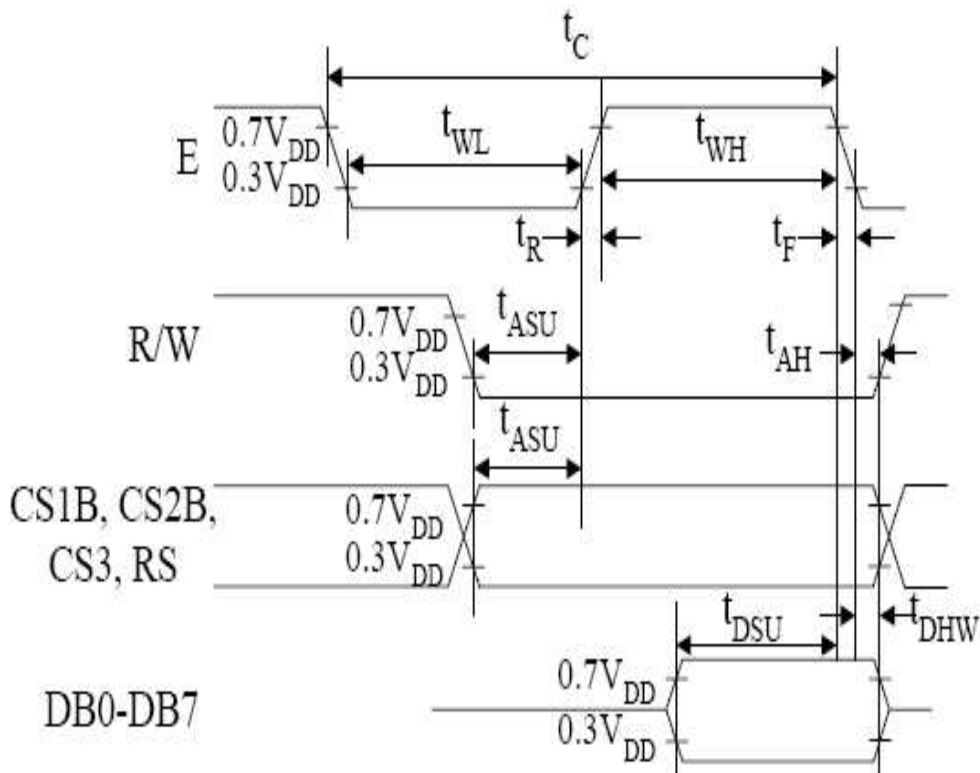

MPU Write Timing

MPU Read Timing

Characteristic	Symbol	Min	Typ	Max	Unit
E cycle	t_C	1000	—	—	ns
E low level width	t_{EWL}	450	—	—	ns
E high level width	t_{EWH}	450	—	—	ns
E rise time	t_R	—	20	—	ns
E fall time	t_F	—	20	—	ns
Address set-up time	t_{AS1}	140	—	—	ns
Address hold time	t_{AH1}	20	—	—	ns
Address set-up time	t_{AS2}	140	—	—	ns
Address hold time	t_{AH2}	10	—	—	ns
Data delay time	t_{DDR}	320	—	—	ns
Data hold time	t_{DHR}	10	—	—	ns

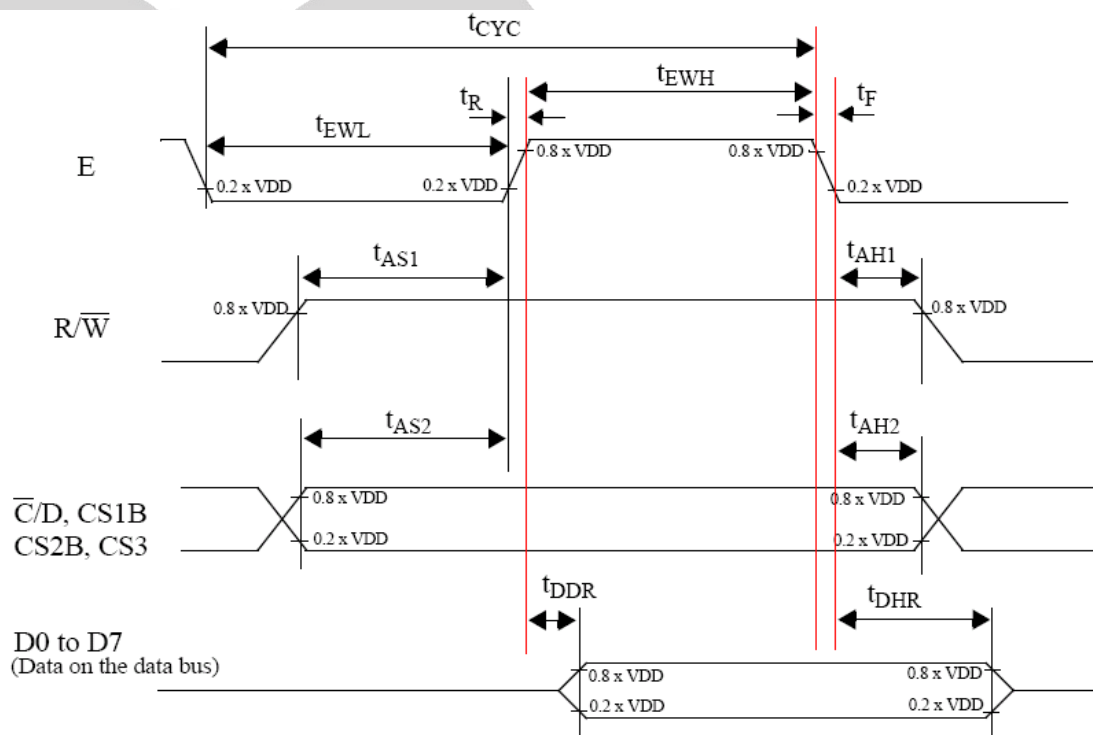

MPU Read Timing